

MAN Diesel | PrimeServ

Benelux

Global and local legislation, limiting the content of sulphur in marine fuels, are getting stricter. With the latest regulations from the EU and Californian Air Resources Board, it is obvious that we are facing a future of more frequent operation of MAN B&W two stroke engines on distillate fuels MGO/MDO.

Guidelines on Operation on Distillate Fuels can be found in our latest Service Letter SL09-515/CXR

MAN B&W two stroke engines can operate on distillate fuel, however following limitations are given:

- Minimum fuel oil viscosity at engine inlet: 2 cSt
- Maximum temperature gradient changing from HFO to MGO and vice versa: 2 deg.C/min.

To ensure safe operation on distillate fuel and to provide the crew with the tools to follow above mentioned limitations, **MAN Diesel | PrimeServ Benelux** is offering a retrofit system consisting of a MGO/MDO cooler system to control viscosity and an automatic change-over between the MDO/MGO and HFO in way of the new developed Diesel Switch.

To be able to comply with the new regulation in California and the future Low Sulphur regulations in Europe, we recommend installing our retrofit system which we call the "CARB package" or "Low sulphur fuel package".

Cooler system:

- Diesel Oil Cooler
- Pipes & Valves
- Thermometers
- Thermo Stems
- Flanges
- Installation
- Pre-inspection

Total Estimate price

€ 23,000 -28,000 *

Diesel Switch:

- Automatic change over valve
- 2 pcs non return valves
- 2 pcs automatic shut off valves
- A static mixer
- A control cabinet
- Pre-inspection

Total Estimate price

€ 30,000 *

* Final price to be quoted after the pre-inspection.

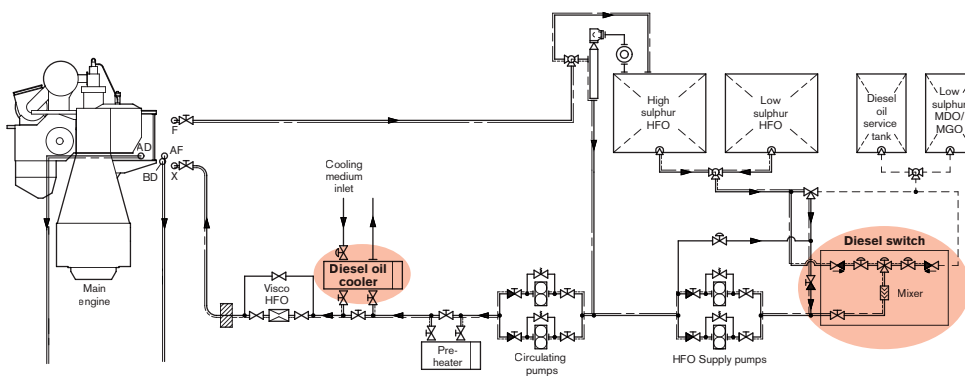

MAN Diesel | PrimeServ Benelux N.V.

Noorderlaan 181
2030 Antwerp
Belgium
Tel.: +32 3 543 85 00
Fax: +32 3 541 75 08

MAN Diesel | PrimeServ Benelux B.V.

Schiekade 36
3125 KJ Schiedam
(Port of Rotterdam)
The Netherlands
Tel.: +31 10 272 4500
Fax: +31 10 437 6115

E-mail:

service-benelux@mandiesel.com
www.mandiesel-benelux.com

Copyright © 2009 MAN Diesel Benelux N.V.
MAN Diesel - a member of the MAN Group

MAN Diesel | PrimeServ Benelux

